

4

3

2

1

REVISIONS			
REV.	DESCRIPTION	DATE	APPROVED
00	INITIAL RELEASE	5/28/24	NK

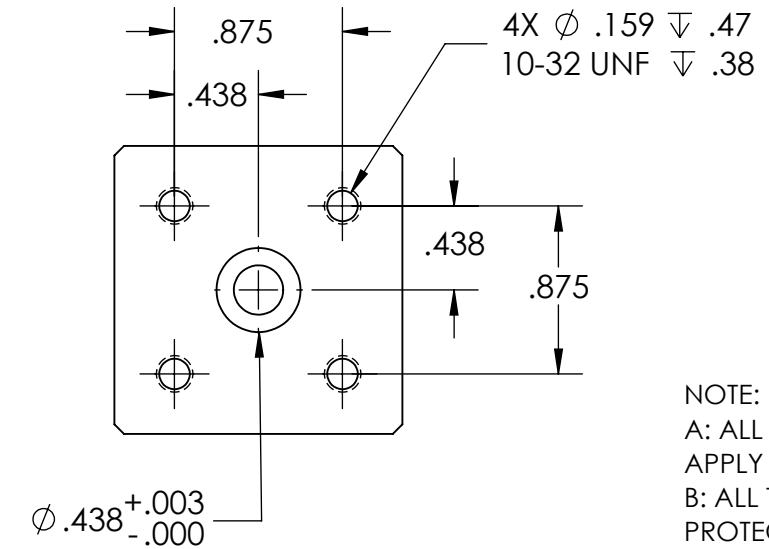
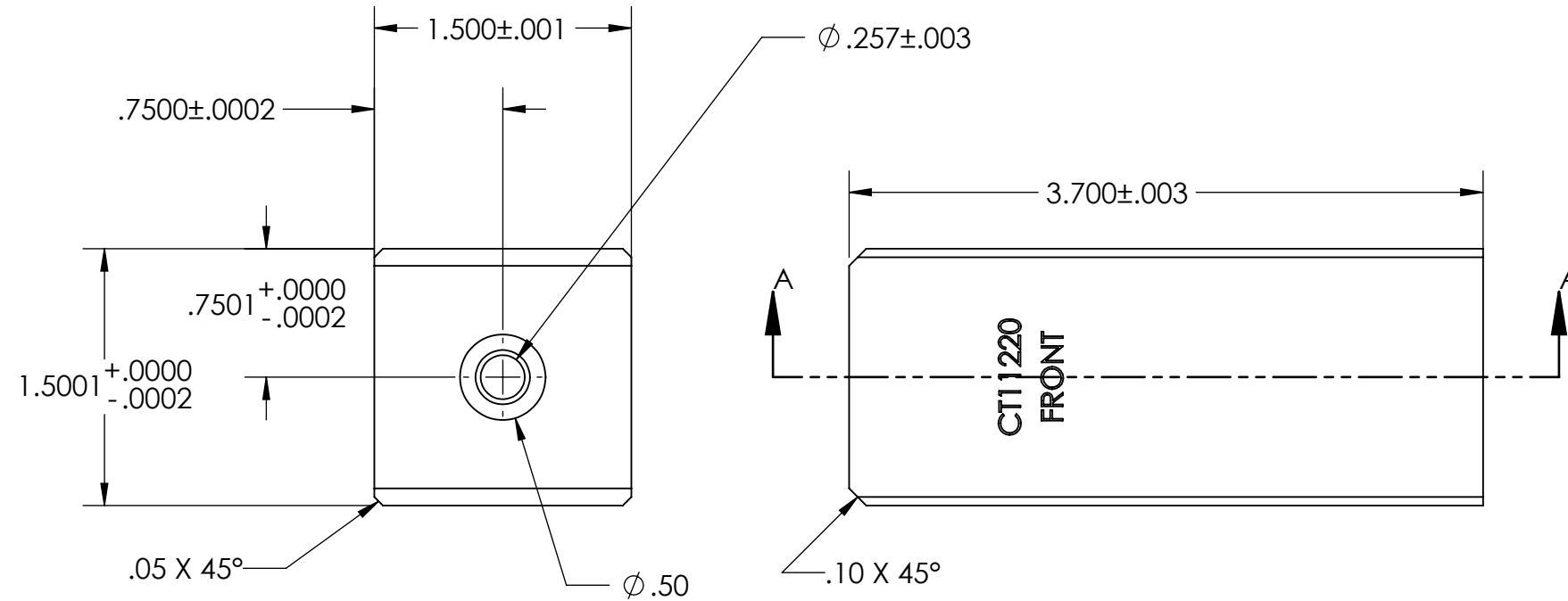
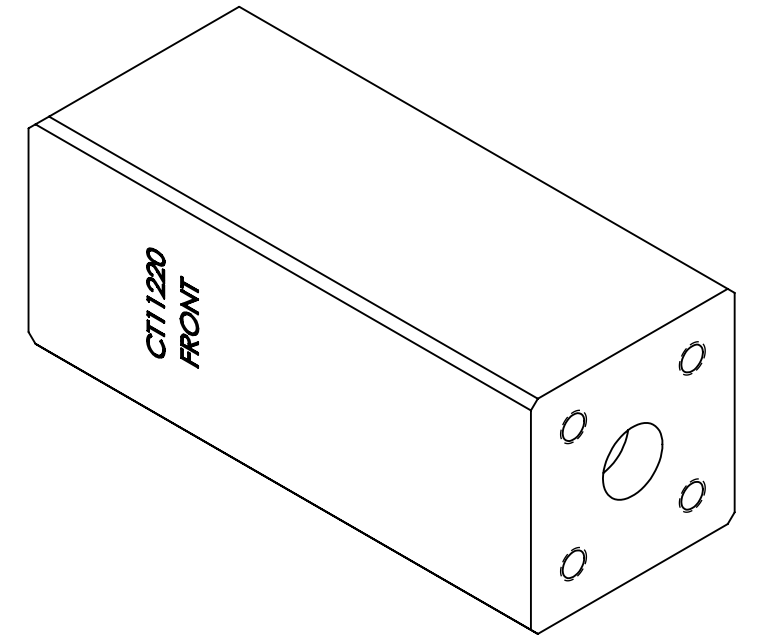
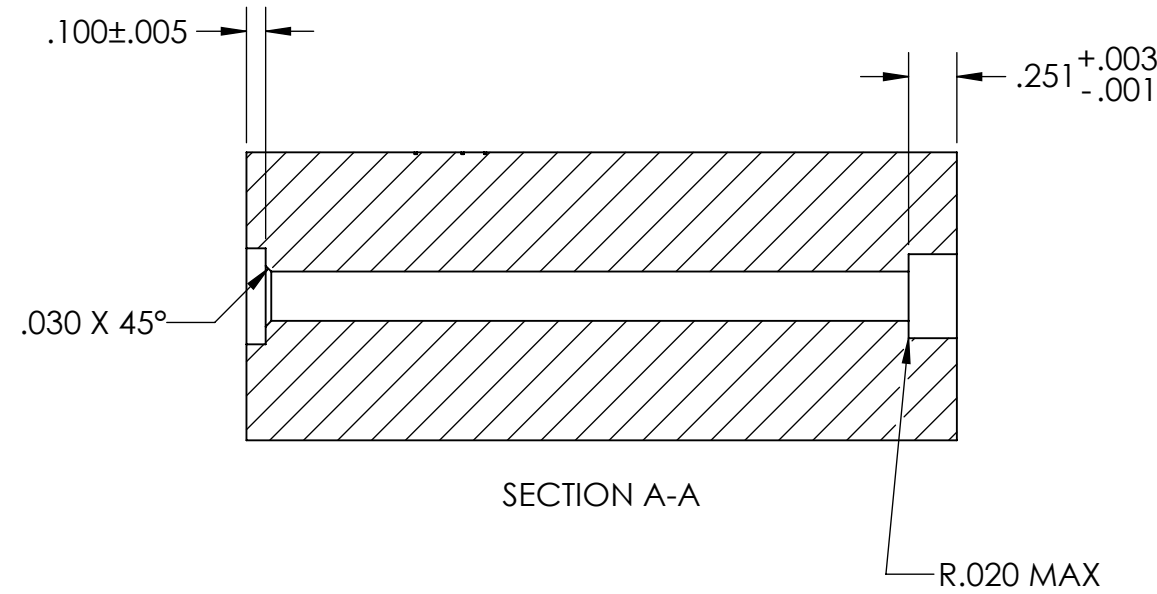

NOTE:
 A: ALL DIMENSION TOLERANCES APPLY AFTER PARTS FINISH
 B: ALL THREADS TO BE PROTECTED FROM COATINGS

QTY:

- NOTES:
 1. BREAK ALL SHARP EDGES
 2. SCRIBE PART NUMBER & REVISION

PROPRIETARY AND CONFIDENTIAL		 THIRD ANGLE PROJECTION	UNLESS OTHERWISE SPECIFIED:		NAME	DATE	 D&M Holding Company
THE INFORMATION CONTAINED IN THIS DRAWING IS THE SOLE PROPERTY OF D&M HOLDING COMPANY. ANY REPRODUCTION IN PART OR AS A WHOLE WITHOUT THE WRITTEN PERMISSION OF D&M HOLDING COMPANY IS PROHIBITED. ALL DRAWINGS AND PRINTS, WHETHER IN PRINTED OR ELECTRONIC FORMAT, MAY ONLY BE USED FOR THE PURPOSE FOR WHICH PERMISSION TO USE WAS GRANTED. THIS DOCUMENT MAY CONTAIN TECHNOLOGY OR TECHNICAL DATA, THE USE OF WHICH IS RESTRICTED BY THE U.S. ARMS EXPORT CONTROL ACT. THIS DATA IS SUBJECT TO THE LIMITATIONS SPECIFIED IN THE INTERNATIONAL TRAFFIC IN ARMS REGULATIONS (ITAR). BY ACCEPTING THIS DATA, THE RECIPIENT AGREES TO HONOR THE REQUIREMENTS OF THE ITAR. THE INFORMATION ON THIS DOCUMENT MAY NOT BE TRANSFERRED TO ANY OTHER COUNTRY, OR TO A NATIONAL OF ANY OTHER COUNTRY, OR OTHERWISE BE DISPOSED OF IN ANY OTHER COUNTRY, EITHER IN THEIR ORIGINAL FORM OR AFTER BEING INCORPORATED INTO OTHER END-ITEMS IS PROHIBITED BY FEDERAL LAW.			DIMENSIONS ARE IN INCHES TOLERANCES: FRACTIONAL $\pm 1/64$ ANGULAR: MACH $\pm .5$ BEND ± 1 ONE PLACE DECIMAL $\pm .05$ TWO PLACE DECIMAL $\pm .01$ THREE PLACE DECIMAL $\pm .005$ FOUR PLACE DECIMAL $\pm .0005$	DRAWN	NK	5/28/2024	
		MATERIAL A2 58-62 HRC	CHECKED			SIZE DWG. NO. REV B CT11220 00	
		FINISH 32 U.O.S.	ENG APPR.			SCALE: 1:1 WEIGHT: 0.29 SHEET 1 OF 1	
		BREAK ALL SHARP EDGES AND DEBURR ALL HOLES .03 MAX	MFG APPR.				
		DO NOT SCALE DRAWING	Q.A.				
			COMMENTS:				

4

3

2

1

B

B

A

A