

4

3

2

1

REVISIONS				
REV.	DESCRIPTION	BY	DATE	APPROVED
00	IMPORTED MODEL	B.F	-	-
1	ADDED FLAT	6/5/2023	6/5/2023	
2	.006 RADIUS WAS .01	6/5/2023	6/5/2023	
3	.0509 WAS .055	6/5/2023	6/5/2023	
4	PART # WAS 02489-03-029 BRUDERER	B.F	6/8/2023	

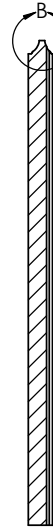
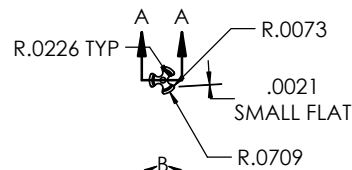
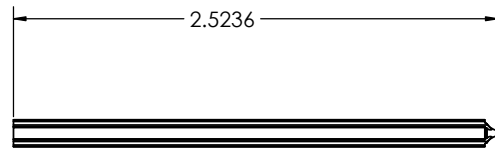

SECTION A-A

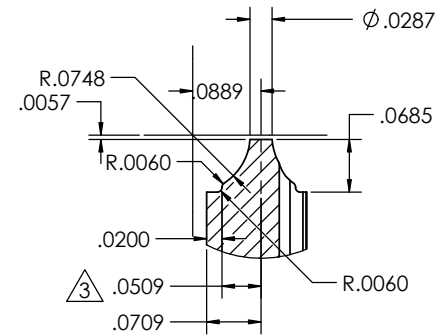

DETAIL B  
SCALE 8 : 1

NOTE:  
 A: ALL DIMENSION TOLERANCES APPLY AFTER PARTS FINISH  
 B: ALL THREADS TO BE PROTECTED FROM COATINGS

QTY: 7+0

<p><b>PROPRIETARY AND CONFIDENTIAL</b></p> <p>THE INFORMATION CONTAINED IN THIS DRAWING IS THE SOLE PROPERTY OF D&amp;M HOLDING COMPANY. ANY REPRODUCTION IN PART OR AS A WHOLE WITHOUT THE WRITTEN PERMISSION OF D&amp;M HOLDING COMPANY IS PROHIBITED.</p> <p>ALL DRAWINGS AND PRINTS, WHETHER IN PRINTED OR ELECTRONIC FORMAT, MAY ONLY BE USED FOR THE PURPOSE FOR WHICH PERMISSION TO USE WAS GRANTED.</p> <p>THIS DOCUMENT MAY CONTAIN TECHNOLOGY OR TECHNICAL DATA, THE USE OF WHICH IS RESTRICTED BY THE U.S. ARMS EXPORT CONTROL ACT. THIS DATA IS SUBJECT TO THE LIMITATIONS SPECIFIED IN THE INTERNATIONAL TRAFFIC IN ARMS REGULATIONS (ITAR). BY ACCEPTING THIS DATA, THE RECIPIENT AGREES TO HONOR THE REQUIREMENTS OF THE ITAR.</p> <p>THE INFORMATION ON THIS DOCUMENT MAY NOT BE TRANSFERRED TO ANY OTHER COUNTRY, OR TO A NATIONAL OF ANY OTHER COUNTRY, OR OTHERWISE BE DISPOSED OF IN ANY OTHER COUNTRY, EITHER IN THEIR ORIGINAL FORM OR AFTER BEING INCORPORATED INTO OTHER END-ITEMS IS PROHIBITED BY FEDERAL LAW.</p>		<p>THIRD ANGLE PROJECTION</p> <p>±.002 F.I.M.</p> <p>±.0005 PER INCH</p> <p>±.001 PER INCH</p> <p>BREAK ALL SHARP EDGES AND DEBURR ALL HOLES .03 MAX</p>	<p>UNLESS OTHERWISE SPECIFIED:          DIMENSIONS ARE IN INCHES          TOLERANCES: FRACTIONAL ±1/64          ANGULAR: MACH ±.5 BEND ±1          ONE PLACE DECIMAL ±.05          TWO PLACE DECIMAL ±.01          THREE PLACE DECIMAL ±.005          FOUR PLACE DECIMAL ±.0005          MATERIAL: CARBIDE CD650 OR =</p> <p>FINISH: √u.o.s.</p> <p>DO NOT SCALE DRAWING</p>	<table border="1"> <tr> <td>DRAWN</td> <td>B.FRANK</td> <td>DATE</td> </tr> <tr> <td>CHECKED</td> <td></td> <td></td> </tr> <tr> <td>ENG APPR</td> <td></td> <td></td> </tr> <tr> <td>MFG APPR</td> <td></td> <td></td> </tr> <tr> <td>G.A.</td> <td></td> <td></td> </tr> </table> <p>COMMENTS:</p>	DRAWN	B.FRANK	DATE	CHECKED			ENG APPR			MFG APPR			G.A.			<p><b>D&amp;M Holding Company</b></p> <p>TITLE: SMALL PISTOL ANVIL</p> <p>SIZE: C DWG. NO. PA0543 REV 4</p> <p>SCALE: 2:1 WEIGHT: 0.00 SHEET 1 OF 1</p>
DRAWN	B.FRANK	DATE																		
CHECKED																				
ENG APPR																				
MFG APPR																				
G.A.																				

4

3

2

1