

4

3

2

1

REVISIONS			
REV.	DESCRIPTION	DATE	APPROVED
00	INITIAL RELEASE	5/2/23	JPF
01	ECO 000000148, $\phi .318 \pm .010$ WAS $\phi .318 \pm .001$	6/5/23	JPF

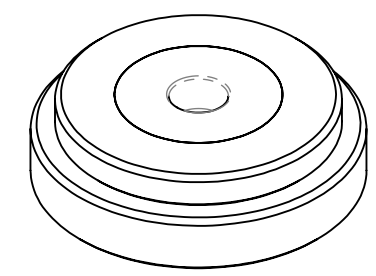
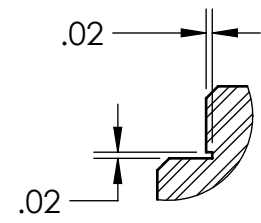
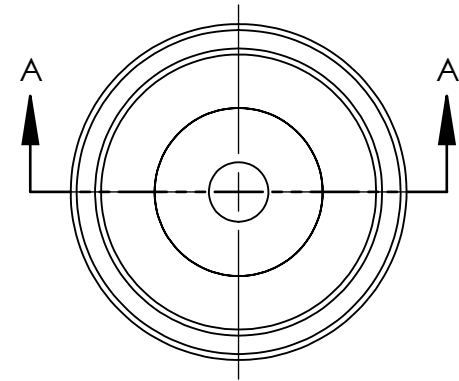

DETAIL B
SCALE 2 : 1

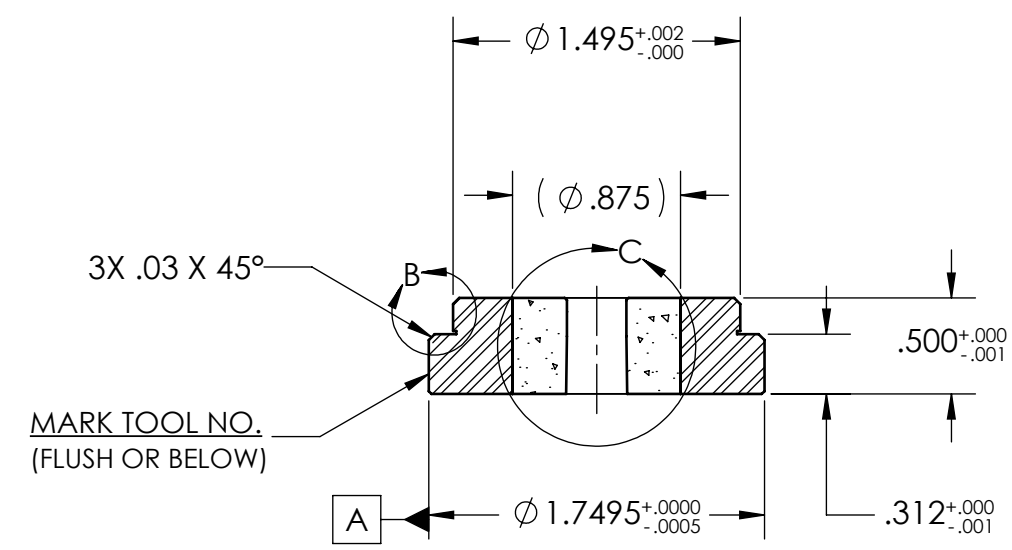

SECTION A-A

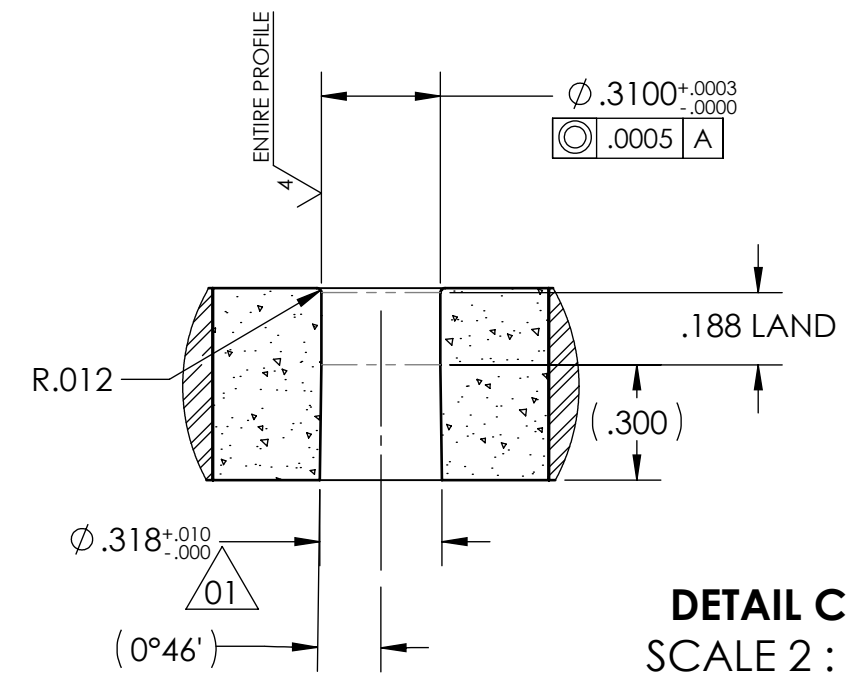

DETAIL C
SCALE 2 : 1

- NOTES:**
- DIE BLANK: 437-00-050-1
 - CARBIDE: GC-813CT
 - CASE: AISI-H13 or AISI-4142 PH
 - HEAT TREAT: Rc 46-50 or Rc 30
 - SURFACE FINISH $\sqrt{16}$ U.O.S.
 - MARK TOOL NO.: 437-05-050-019 REV 01

<p>THE INFORMATION CONTAINED IN THIS DRAWING IS THE SOLE PROPERTY OF D&M HOLDING COMPANY. ANY REPRODUCTION IN PART OR AS A WHOLE WITHOUT THE WRITTEN PERMISSION OF D&M HOLDING COMPANY IS PROHIBITED.</p> <p>ALL DRAWINGS AND PRINTS, WHETHER IN PRINTED OR ELECTRONIC FORMAT, MAY ONLY BE USED FOR THE PURPOSE FOR WHICH PERMISSION TO USE WAS GRANTED.</p> <p>THIS DOCUMENT MAY CONTAIN TECHNOLOGY OR TECHNICAL DATA, THE USE OF WHICH IS RESTRICTED BY THE U.S. ARMS EXPORT CONTROL ACT. THIS DATA IS SUBJECT TO THE LIMITATIONS SPECIFIED IN THE INTERNATIONAL TRAFFIC IN ARMS REGULATIONS (ITAR). BY ACCEPTING THIS DATA, THE RECIPIENT AGREES TO HONOR THE REQUIREMENTS OF THE ITAR.</p> <p>THE INFORMATION ON THIS DOCUMENT MAY NOT BE TRANSFERRED TO ANY OTHER COUNTRY, OR TO A NATIONAL OF ANY OTHER COUNTRY, OR OTHERWISE BE DISPOSED OF IN ANY OTHER COUNTRY, EITHER IN THEIR ORIGINAL FORM OR AFTER BEING INCORPORATED INTO OTHER END-ITEMS IS PROHIBITED BY FEDERAL LAW.</p>	<p>UNLESS OTHERWISE SPECIFIED:</p> <p>DIMENSIONS ARE IN INCHES</p> <p>TOLERANCES:</p> <p>FRACTIONAL $\pm 1/64$</p> <p>ANGULAR: MACH $\pm .5$ BEND ± 1</p> <p>TWO PLACE DECIMAL $\pm .01$</p> <p>THREE PLACE DECIMAL $\pm .002$</p> <p>FOUR PLACE DECIMAL $\pm .0005$</p> <p>BREAK ALL SHARP CORNERS .01" UNLESS OTHERWISE NOTED</p>	<table border="1"> <tr> <td>NAME</td> <td>DATE</td> </tr> <tr> <td>JPF</td> <td>5/2/23</td> </tr> </table>	NAME	DATE	JPF	5/2/23	<p>D&M Holding Company</p> <p>TITLE: DIE, PRE-CLIP, .310, .012 U.S. BAIRD 4L-37</p>													
	NAME	DATE																		
	JPF	5/2/23																		
	<p>DO NOT SCALE DRAWING</p>	<table border="1"> <tr> <td>DRAWN</td> <td></td> </tr> <tr> <td>CHECKED</td> <td></td> </tr> <tr> <td>ENG APPR.</td> <td></td> </tr> <tr> <td>MFG APPR.</td> <td></td> </tr> <tr> <td>Q.A.</td> <td></td> </tr> <tr> <td>COMMENTS:</td> <td></td> </tr> </table>	DRAWN		CHECKED			ENG APPR.		MFG APPR.		Q.A.		COMMENTS:		<table border="1"> <tr> <td>SIZE</td> <td>DWG. NO.</td> <td>REV</td> </tr> <tr> <td>B</td> <td>437-05-050-019</td> <td>01</td> </tr> </table>	SIZE	DWG. NO.	REV	B
DRAWN																				
CHECKED																				
ENG APPR.																				
MFG APPR.																				
Q.A.																				
COMMENTS:																				
SIZE	DWG. NO.	REV																		
B	437-05-050-019	01																		
		<table border="1"> <tr> <td>SCALE: 1:1</td> <td>WEIGHT:</td> <td>SHEET 1 OF 1</td> </tr> </table>	SCALE: 1:1	WEIGHT:	SHEET 1 OF 1															
SCALE: 1:1	WEIGHT:	SHEET 1 OF 1																		

4

3

2

1