

4

3

2

1

REVISIONS			
REV.	DESCRIPTION	DATE	APPROVED
A	INITIAL RELEASE	10/5/20	JPF
B	1.115 WAS 1.120, .990 WAS .995	11/20/20	JPF

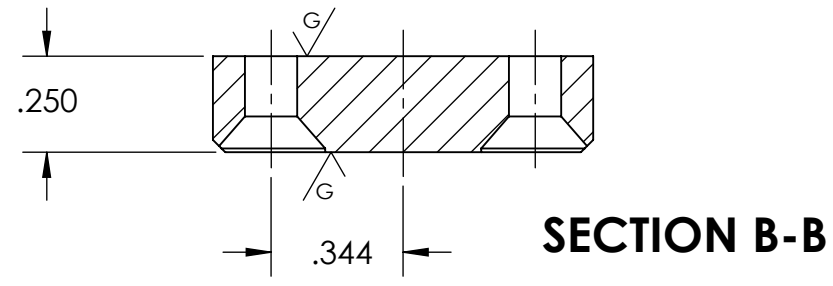
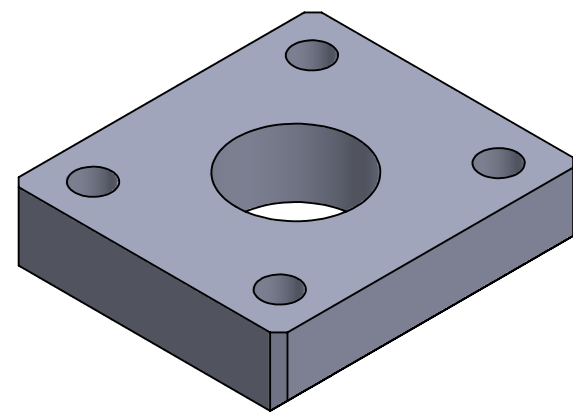
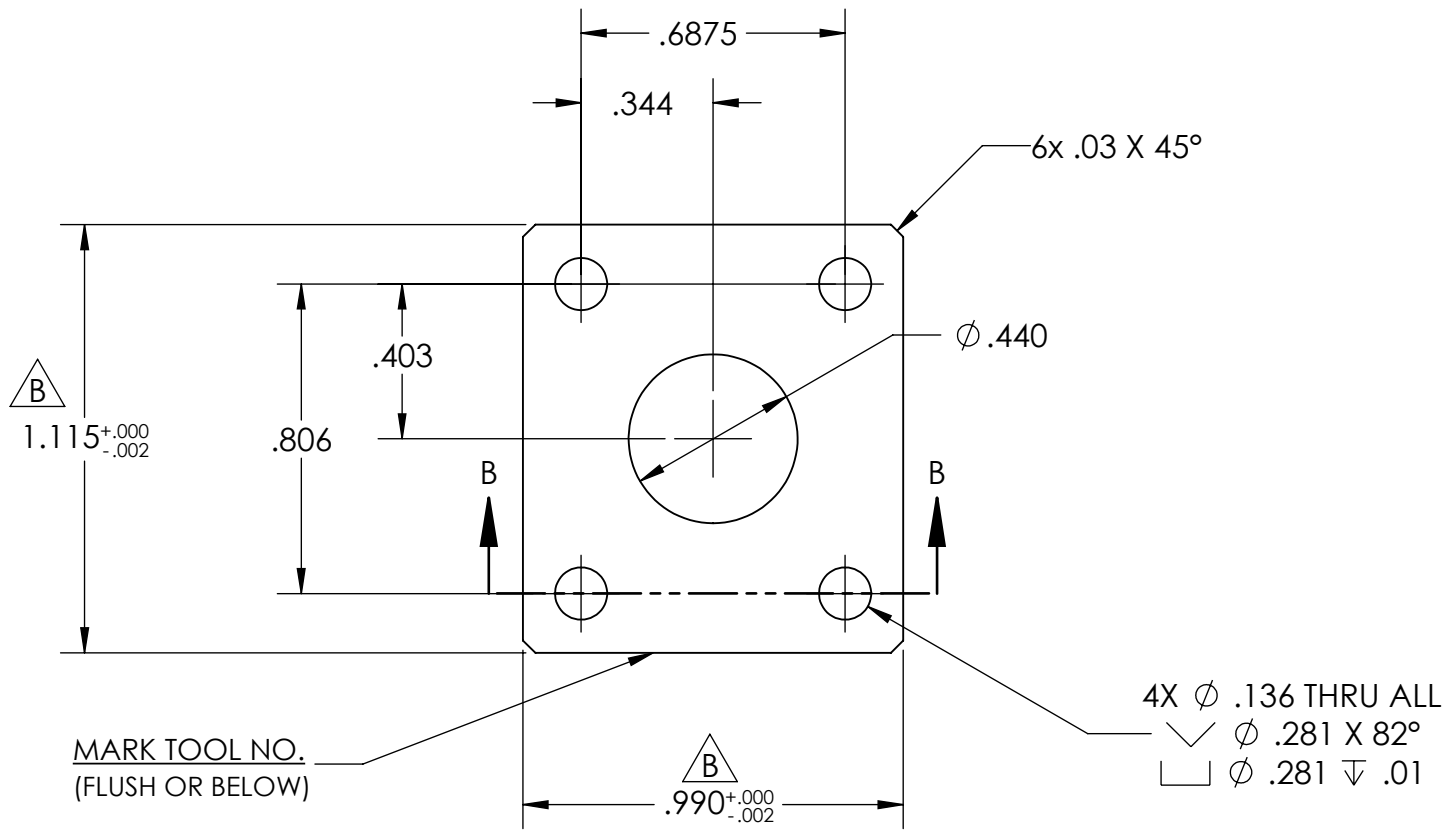

- NOTES:**
- MATERIAL: AISI-A2
  - HEAT TREAT: Rc 58-60
  - SURFACE FINISH  $\sqrt{16}$  U.O.S.
  - MARK TOOL NO.: 325-09-002 REV B

THE INFORMATION CONTAINED IN THIS DRAWING IS THE SOLE PROPERTY OF D&M HOLDING COMPANY. ANY REPRODUCTION IN PART OR AS A WHOLE WITHOUT THE WRITTEN PERMISSION OF D&M HOLDING COMPANY IS PROHIBITED.

ALL DRAWINGS AND PRINTS, WHETHER IN PRINTED OR ELECTRONIC FORMAT, MAY ONLY BE USED FOR THE PURPOSE FOR WHICH PERMISSION TO USE WAS GRANTED.

THIS DOCUMENT MAY CONTAIN TECHNOLOGY OR TECHNICAL DATA, THE USE OF WHICH IS RESTRICTED BY THE U.S. ARMS EXPORT CONTROL ACT. THIS DATA IS SUBJECT TO THE LIMITATIONS SPECIFIED IN THE INTERNATIONAL TRAFFIC IN ARMS REGULATIONS (ITAR). BY ACCEPTING THIS DATA, THE RECIPIENT AGREES TO HONOR THE REQUIREMENTS OF THE ITAR.

THE INFORMATION ON THIS DOCUMENT MAY NOT BE TRANSFERRED TO ANY OTHER COUNTRY, OR TO A NATIONAL OF ANY OTHER COUNTRY, OR OTHERWISE BE DISPOSED OF IN ANY OTHER COUNTRY, EITHER IN THEIR ORIGINAL FORM OR AFTER BEING INCORPORATED INTO OTHER END-ITEMS IS PROHIBITED BY FEDERAL LAW.

UNLESS OTHERWISE SPECIFIED:	NAME	DATE
DIMENSIONS ARE IN INCHES	DRAWN	JPF 10/5/20
TOLERANCES:	CHECKED	
FRACTIONAL ± 1/64	ENG APPR.	
ANGULAR: MACH ± .5 BEND ± 1	MFG APPR.	
TWO PLACE DECIMAL ± .01	Q.A.	
THREE PLACE DECIMAL ± .002	COMMENTS:	
FOUR PLACE DECIMAL ± .0005		
BREAK ALL SHARP CORNERS .01" UNLESS OTHERWISE NOTED		
DO NOT SCALE DRAWING		

**D&M Holding Company**

TITLE: **BOTTOM PLATE, STL CORE & CNL'R P.H. U.S. BAIRD 3-25**

SIZE	DWG. NO.	REV
<b>B</b>	325-09-003	<b>B</b>
SCALE: 2:1	WEIGHT:	SHEET 1 OF 1

4

3

2

1

A

A