

4

3

2

1

REVISIONS			
REV.	DESCRIPTION	DATE	APPROVED
00	INITIAL RELEASE	3/20/23	NK

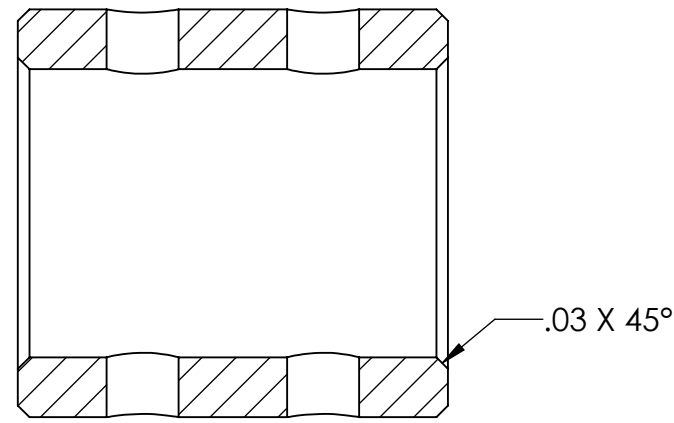

SECTION A-A

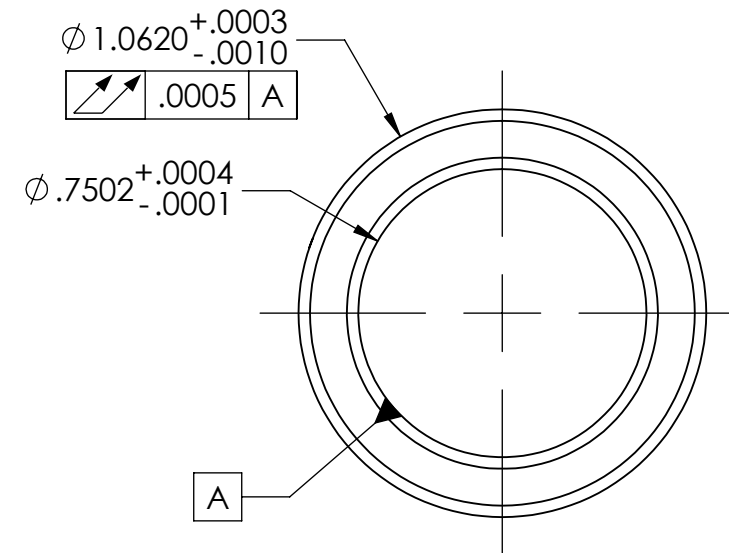
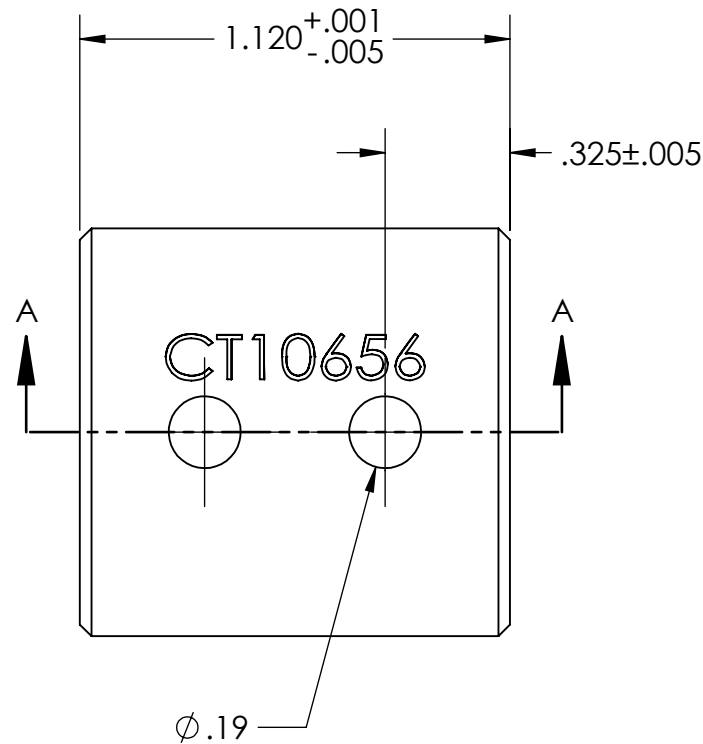

NOTE:  
 A: ALL DIMENSION TOLERANCES APPLY AFTER PARTS FINISH  
 B: ALL THREADS TO BE PROTECTED FROM COATINGS

QTY: 1

NOTES:

- BOTH ENDS ARE SYMETRIC
- SCRIBE PN & REVISION ON OUTSIDE DIAMETER
- 

<b>PROPRIETARY AND CONFIDENTIAL</b>		<p>THIRD ANGLE PROJECTION</p>	UNLESS OTHERWISE SPECIFIED: DIMENSIONS ARE IN INCHES TOLERANCES: FRACTIONAL ±1/64 ANGULAR: MACH ±.5 BEND ±1 ONE PLACE DECIMAL ±.05 TWO PLACE DECIMAL ±.01 THREE PLACE DECIMAL ±.005 FOUR PLACE DECIMAL ±.0005	NAME	DATE	
THE INFORMATION CONTAINED IN THIS DRAWING IS THE SOLE PROPERTY OF D&M HOLDING COMPANY. ANY REPRODUCTION OR TRANSMISSION OF THIS DRAWING IN ANY FORM OR BY ANY MEANS, WITHOUT THE WRITTEN PERMISSION OF D&M HOLDING COMPANY IS PROHIBITED.  ALL DRAWINGS AND PRINTS, WHETHER IN PRINTED OR ELECTRONIC FORMAT, MAY ONLY BE USED FOR THE PURPOSE FOR WHICH PERMISSION TO USE WAS GRANTED.  THIS DOCUMENT MAY CONTAIN TECHNOLOGY OR TECHNICAL DATA, THE USE OF WHICH IS RESTRICTED BY THE U.S. ARMS EXPORT CONTROL ACT. THIS DATA IS SUBJECT TO THE LIMITATIONS SPECIFIED IN THE INTERNATIONAL TRAFFIC IN ARMS REGULATIONS (ITAR). BY ACCEPTING THIS DATA, THE RECIPIENT AGREES TO HONOR THE REQUIREMENTS OF THE ITAR.  THE INFORMATION ON THIS DOCUMENT MAY NOT BE TRANSFERRED TO ANY OTHER COUNTRY, OR TO A NATIONAL OF ANY OTHER COUNTRY, OR OTHERWISE BE DISPOSED OF IN ANY OTHER COUNTRY, EITHER IN THEIR ORIGINAL FORM OR AFTER BEING INCORPORATED INTO OTHER END-ITEMS IS PROHIBITED BY FEDERAL LAW.				DRAWN NK 9/8/2022 CHECKED ENG APPR. MFG APPR. Q.A. COMMENTS:	TITLE: <b>2-PIECE TAPER DIE RETAINER SLEEVE 6.5 CREEDMOOR</b>	
±.002 F.I.M. // ±.0005 PER INCH ⊥ ±.001 PER INCH BREAK ALL SHARP EDGES AND DEBURR ALL HOLES .03 MAX	MATERIAL A2 58-61 HRC	FINISH 32 U.O.S.	DO NOT SCALE DRAWING	SIZE <b>B</b>	DWG. NO. <b>CT10656</b>	REV <b>00</b>
		SCALE: 2:1	WEIGHT: 0.02	SHEET 1 OF 1		

4

3

2

1