

4

3

2

1

LATEST REVISION

Revision	Description	Revised By	Revision Date	Approved By	ECO Number
00	INITAL RELEASE				

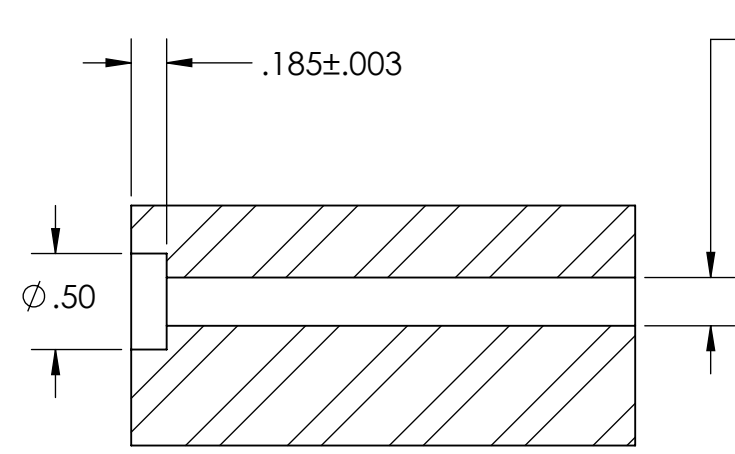

SECTION A-A

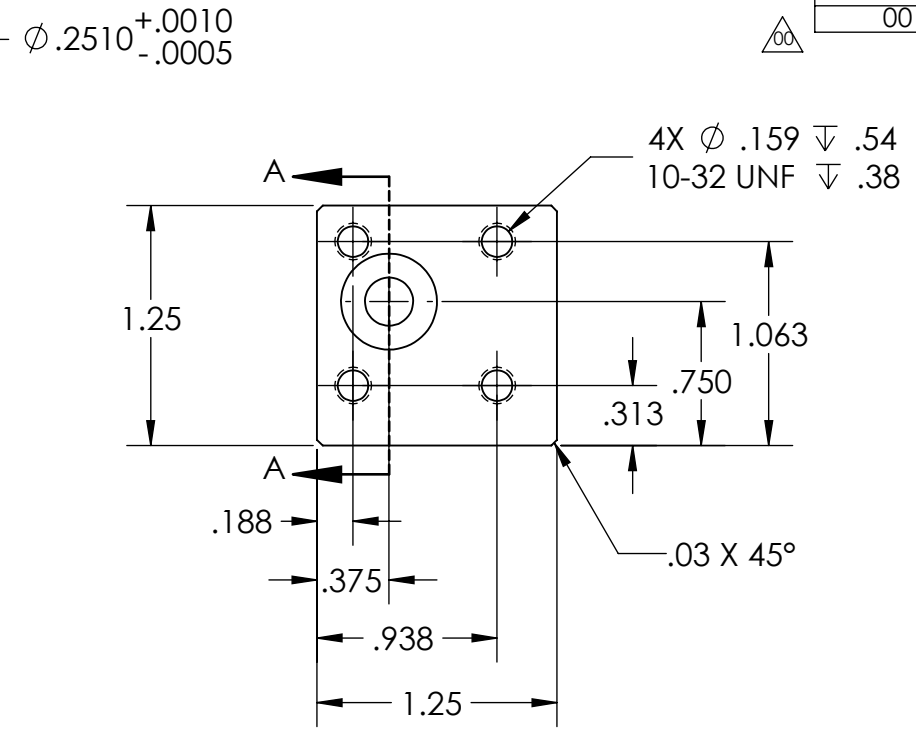

2X ϕ .201 ∇ .65
 1/4-20 UNC ∇ .50

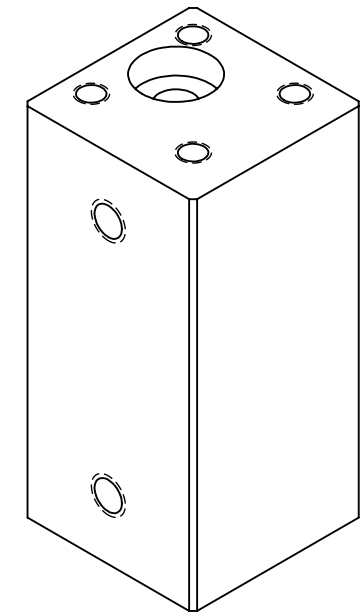
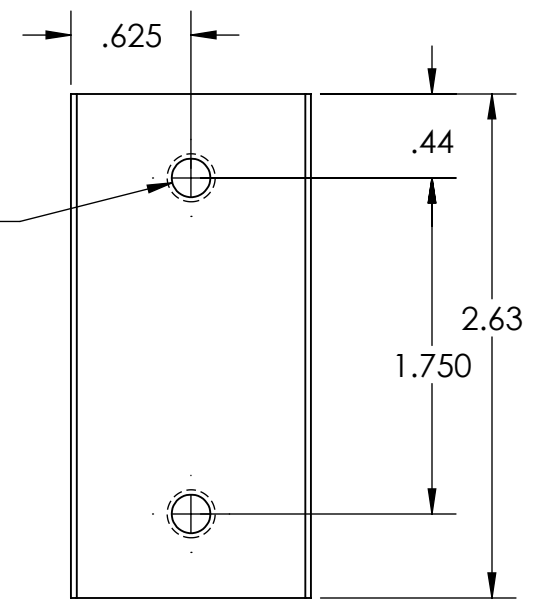

NOTE:
 A: ALL DIMENSION TOLERANCES APPLY AFTER PARTS FINISH
 B: ALL THREADS TO BE PROTECTED FROM COATINGS

QTY:

<p>PROPRIETARY AND CONFIDENTIAL</p> <p>THE INFORMATION CONTAINED IN THIS DRAWING IS THE SOLE PROPERTY OF D&M HOLDING COMPANY. ANY REPRODUCTION IN PART OR AS A WHOLE WITHOUT THE WRITTEN PERMISSION OF D&M HOLDING COMPANY IS PROHIBITED.</p> <p>ALL DRAWINGS AND PRINTS, WHETHER IN PRINTED OR ELECTRONIC FORMAT, MAY ONLY BE USED FOR THE PURPOSE FOR WHICH PERMISSION TO USE WAS GRANTED.</p> <p>THIS DOCUMENT MAY CONTAIN TECHNOLOGY OR TECHNICAL DATA, THE USE OF WHICH IS RESTRICTED BY THE U.S. ARMS EXPORT CONTROL ACT. THIS DATA IS SUBJECT TO THE LIMITATIONS SPECIFIED IN THE INTERNATIONAL TRAFFIC IN ARMS REGULATIONS (ITAR). BY ACCEPTING THIS DATA, THE RECIPIENT AGREES TO HONOR THE REQUIREMENTS OF THE ITAR.</p> <p>THE INFORMATION ON THIS DOCUMENT MAY NOT BE TRANSFERRED TO ANY OTHER COUNTRY, OR TO A NATIONAL OF ANY OTHER COUNTRY, OR OTHERWISE BE DISPOSED OF IN ANY OTHER COUNTRY, EITHER IN THEIR ORIGINAL FORM OR AFTER BEING INCORPORATED INTO OTHER END-ITEMS IS PROHIBITED BY FEDERAL LAW.</p>	<p>THIRD ANGLE PROJECTION</p> <p>C \pm.002 F.I.M.</p> <p>H \pm.0005 PER INCH</p> <p>L \pm.001 PER INCH</p> <p>BREAK ALL SHARP EDGES AND DEBURR ALL HOLES .03 MAX</p>	<p>UNLESS OTHERWISE SPECIFIED:</p> <p>DIMENSIONS ARE IN INCHES</p> <p>TOLERANCES: FRACTIONAL \pm1/64</p> <p>ANGULAR: MACH \pm.5 BEND \pm1</p> <p>ONE PLACE DECIMAL \pm.05</p> <p>TWO PLACE DECIMAL \pm.01</p> <p>THREE PLACE DECIMAL \pm.005</p> <p>FOUR PLACE DECIMAL \pm.0005</p>	<table border="1"> <tr><td>NAME</td><td>DATE</td></tr> <tr><td>DRAWN</td><td>5/28/2024</td></tr> <tr><td>CHECKED</td><td></td></tr> <tr><td>ENG APPR.</td><td></td></tr> <tr><td>MFG APPR.</td><td></td></tr> <tr><td>Q.A.</td><td></td></tr> <tr><td>MAKE/BUY</td><td></td></tr> <tr><td>COATING</td><td></td></tr> <tr><td>COMMENTS:</td><td></td></tr> </table>	NAME	DATE	DRAWN	5/28/2024	CHECKED		ENG APPR.		MFG APPR.		Q.A.		MAKE/BUY		COATING		COMMENTS:		
		NAME	DATE																			
		DRAWN	5/28/2024																			
		CHECKED																				
		ENG APPR.																				
MFG APPR.																						
Q.A.																						
MAKE/BUY																						
COATING																						
COMMENTS:																						
		MATERIAL		DESCRIPTION:																		
		4140 PH		STATION 15 EJECT PUNCH HOLDER 4L-37 14 STATION																		
		FINISH		SIZE DWG. NO. REV																		
		125 \sqrt u.o.s.		B CT11225 00																		
		DO NOT SCALE DRAWING		SCALE: 1:1 WEIGHT: 1.09 SHEET 1 OF 1																		

4

3

2

1