

4

3

2

1

LATEST REVISION					
Revision	Description	Revised By	Revision Date	Approved By	ECO Number
01	.3505 WAS .3480, .2465 WAS .2460, .3733 WAS .3730		8/26/24	NK	

B

B

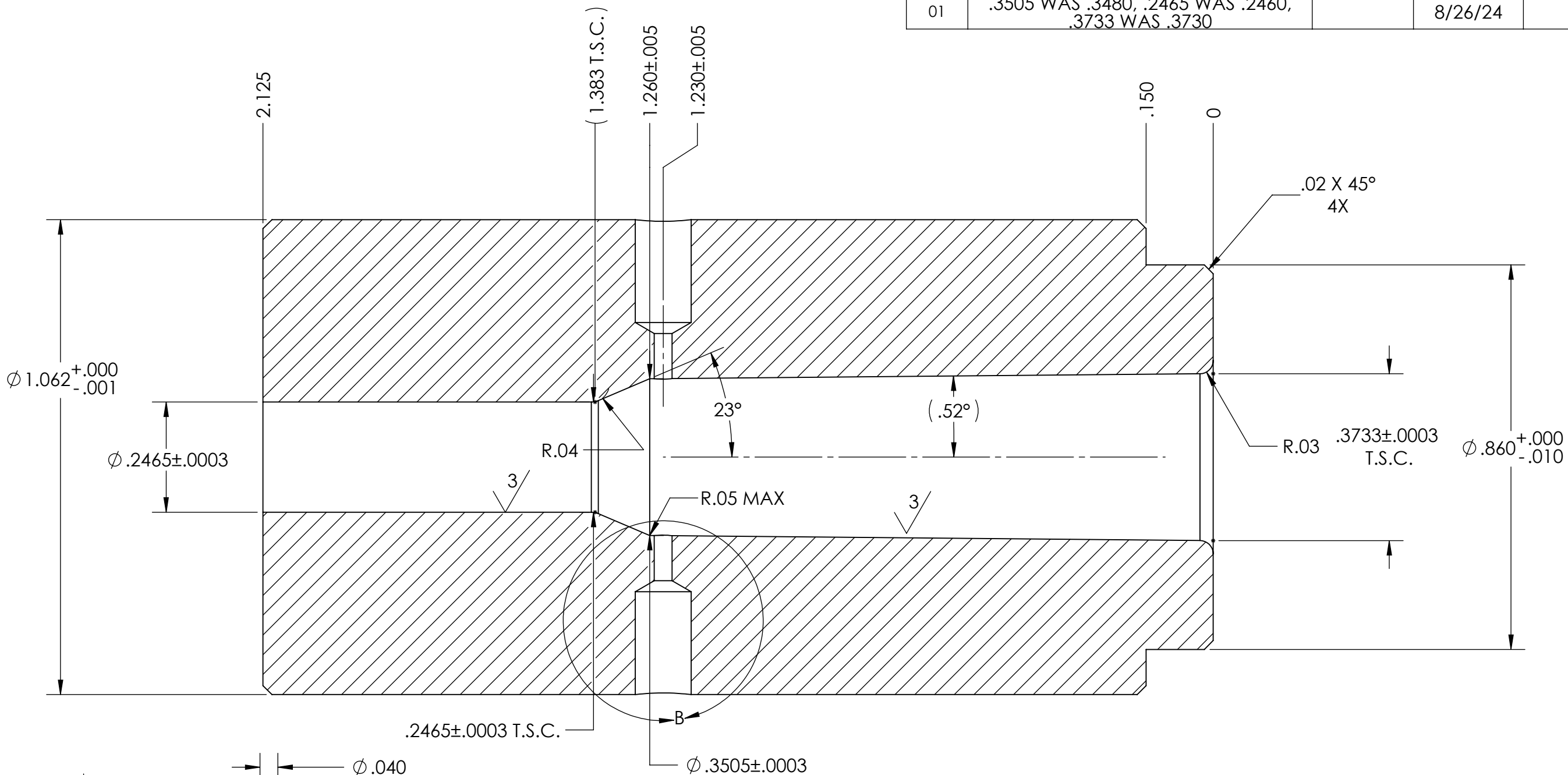

A

A

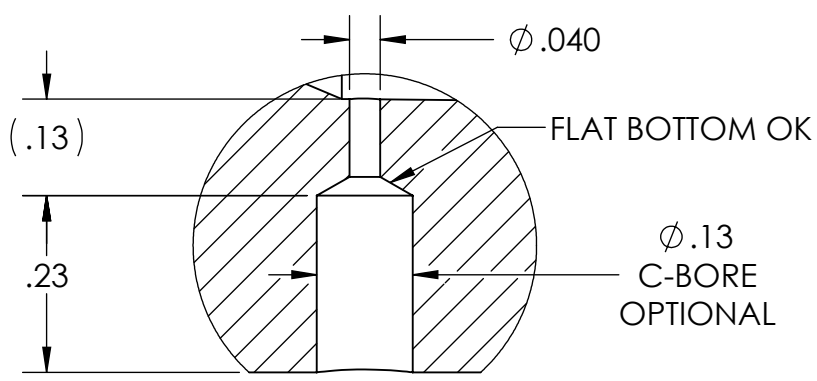

DETAIL B

THE INFORMATION CONTAINED IN THIS DRAWING IS THE SOLE PROPERTY OF D&M HOLDING COMPANY. ANY REPRODUCTION IN PART OR AS A WHOLE WITHOUT THE WRITTEN PERMISSION OF D&M HOLDING COMPANY IS PROHIBITED.

ALL DRAWINGS AND PRINTS, WHETHER IN PRINTED OR ELECTRONIC FORMAT, MAY ONLY BE USED FOR THE PURPOSE FOR WHICH PERMISSION TO USE WAS GRANTED.

THIS DOCUMENT MAY CONTAIN TECHNOLOGY OR TECHNICAL DATA, THE USE OF WHICH IS RESTRICTED BY THE U.S. ARMS EXPORT CONTROL ACT. THIS DATA IS SUBJECT TO THE LIMITATIONS SPECIFIED IN THE INTERNATIONAL TRAFFIC IN ARMS REGULATIONS (ITAR). BY ACCEPTING THIS DATA, THE RECIPIENT AGREES TO HONOR THE REQUIREMENTS OF THE ITAR.

THE INFORMATION ON THIS DOCUMENT MAY NOT BE TRANSFERRED TO ANY OTHER COUNTRY, OR TO A NATIONAL OF ANY OTHER COUNTRY, OR OTHERWISE BE DISPOSED OF IN ANY OTHER COUNTRY, EITHER IN THEIR ORIGINAL FORM OR AFTER BEING INCORPORATED INTO OTHER END-ITEMS IS PROHIBITED BY FEDERAL LAW.

UNLESS OTHERWISE SPECIFIED:
 DIMENSIONS ARE IN INCHES
 TOLERANCES:
 FRACTIONAL $\pm 1/64$
 ANGULAR: MACH $\pm .5$ BEND ± 1
 TWO PLACE DECIMAL $\pm .01$
 THREE PLACE DECIMAL $\pm .002$
 FOUR PLACE DECIMAL $\pm .0005$

BREAK ALL SHARP CORNERS .01" UNLESS OTHERWISE NOTED

MATERIAL GC813CT OR EQUIVALENT

FINISH 63

DO NOT SCALE DRAWING

	NAME	DATE
DRAWN	NK	7/31/24
CHECKED		
ENG APPR.		
MFG APPR.		
Q.A.		
COMMENTS:		

D&M Holding Company

TITLE:
5.56 NATO FINAL TAPER DIE V2

SIZE	DWG. NO.	REV
B	CT10205	01

SCALE: 4:1 WEIGHT: 0.060.06 SHEET 1 OF 1

4

3

2

1