

4

3

2

1

REVISIONS			
REV.	DESCRIPTION	DATE	APPROVED
A	INITIAL RELEASE	3/1/21	JPF

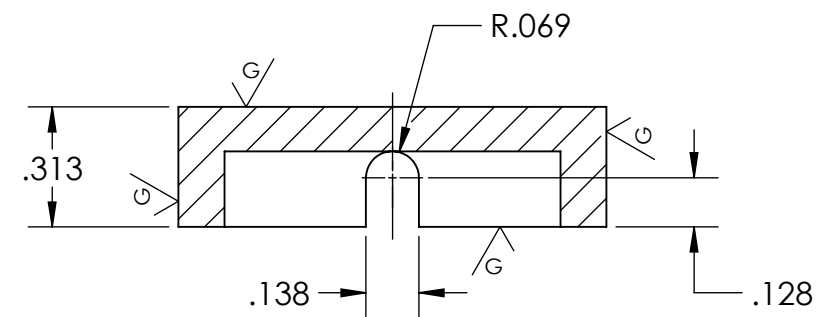
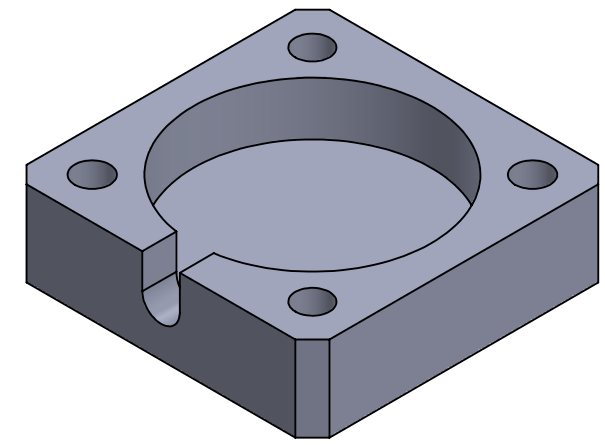
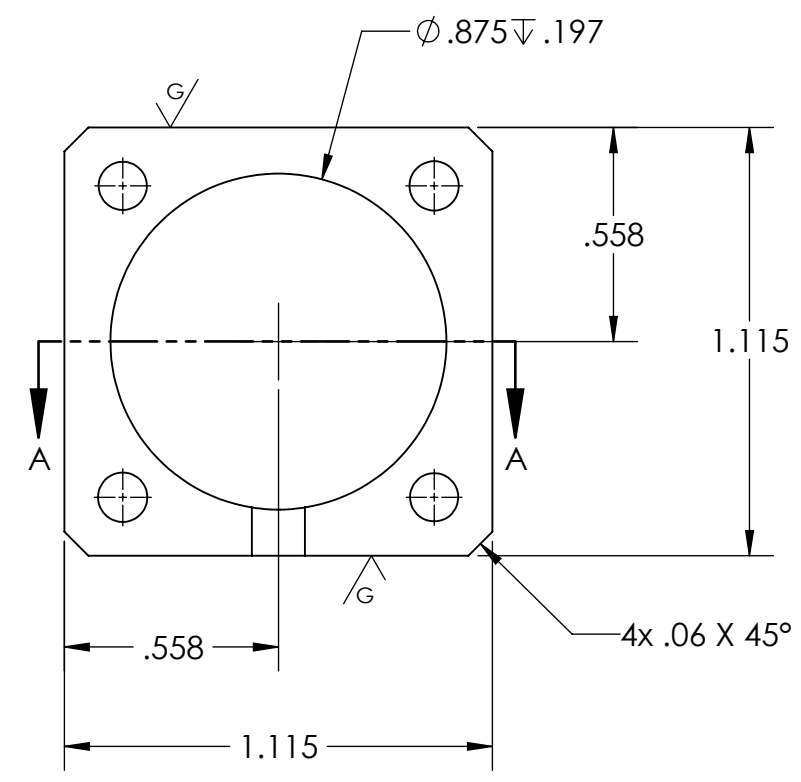

SECTION A-A

MARK TOOL NO.
(FLUSH OR BELOW)

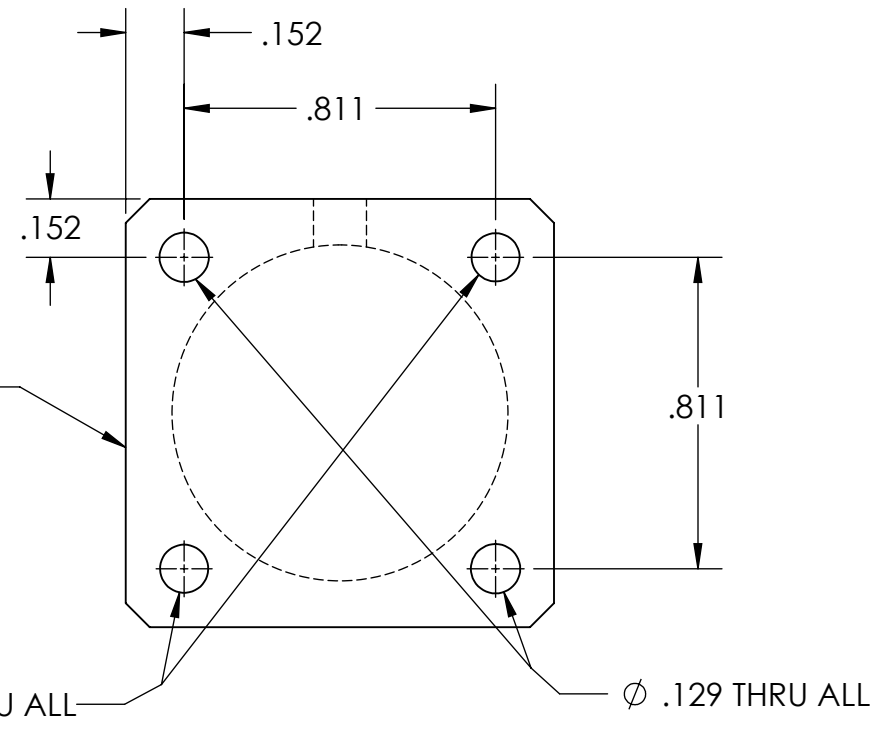

NOTES:

1. MATERIAL: AISI-A2
2. HEAT TREAT: Rc 58-60
3. SURFACE FINISH $\sqrt{16}$ U.O.S.
4. MARK TOOL NO.: 325-11-002-14 REV A

<p>THE INFORMATION CONTAINED IN THIS DRAWING IS THE SOLE PROPERTY OF D&M HOLDING COMPANY. ANY REPRODUCTION IN PART OR AS A WHOLE WITHOUT THE WRITTEN PERMISSION OF D&M HOLDING COMPANY IS PROHIBITED.</p> <p>ALL DRAWINGS AND PRINTS, WHETHER IN PRINTED OR ELECTRONIC FORMAT, MAY ONLY BE USED FOR THE PURPOSE FOR WHICH PERMISSION TO USE WAS GRANTED.</p> <p>THIS DOCUMENT MAY CONTAIN TECHNOLOGY OR TECHNICAL DATA, THE USE OF WHICH IS RESTRICTED BY THE U.S. ARMS EXPORT CONTROL ACT. THIS DATA IS SUBJECT TO THE LIMITATIONS SPECIFIED IN THE INTERNATIONAL TRAFFIC IN ARMS REGULATIONS (ITAR). BY ACCEPTING THIS DATA, THE RECIPIENT AGREES TO HONOR THE REQUIREMENTS OF THE ITAR.</p> <p>THE INFORMATION ON THIS DOCUMENT MAY NOT BE TRANSFERRED TO ANY OTHER COUNTRY, OR TO A NATIONAL OF ANY OTHER COUNTRY, OR OTHERWISE BE DISPOSED OF IN ANY OTHER COUNTRY, EITHER IN THEIR ORIGINAL FORM OR AFTER BEING INCORPORATED INTO OTHER END-ITEMS IS PROHIBITED BY FEDERAL LAW.</p>	UNLESS OTHERWISE SPECIFIED:	NAME	DATE	<p>TITLE: SENSOR PLATE, SEATING P.H. U.S. BAIRD 3-25</p>	
	DIMENSIONS ARE IN INCHES TOLERANCES: FRACTIONAL $\pm 1/64$ ANGULAR: MACH $\pm .5$ BEND ± 1 TWO PLACE DECIMAL $\pm .01$ THREE PLACE DECIMAL $\pm .002$ FOUR PLACE DECIMAL $\pm .0005$	DRAWN	JPF		3/1/21
	BREAK ALL SHARP CORNERS .01" UNLESS OTHERWISE NOTED	CHECKED			
		ENG APPR.			
	MFG APPR.				
	Q.A.				
	COMMENTS:				
	DO NOT SCALE DRAWING				

SIZE	DWG. NO.	REV
B	325-11-002-14	A
SCALE: 2:1	WEIGHT:	SHEET 1 OF 1

4

3

2

1

B

B

A

A