

4

3

2

1

LATEST REVISION

Revision	Description	Revised By	Revision Date	Approved By	ECO Number
00	-	-	-	-	-

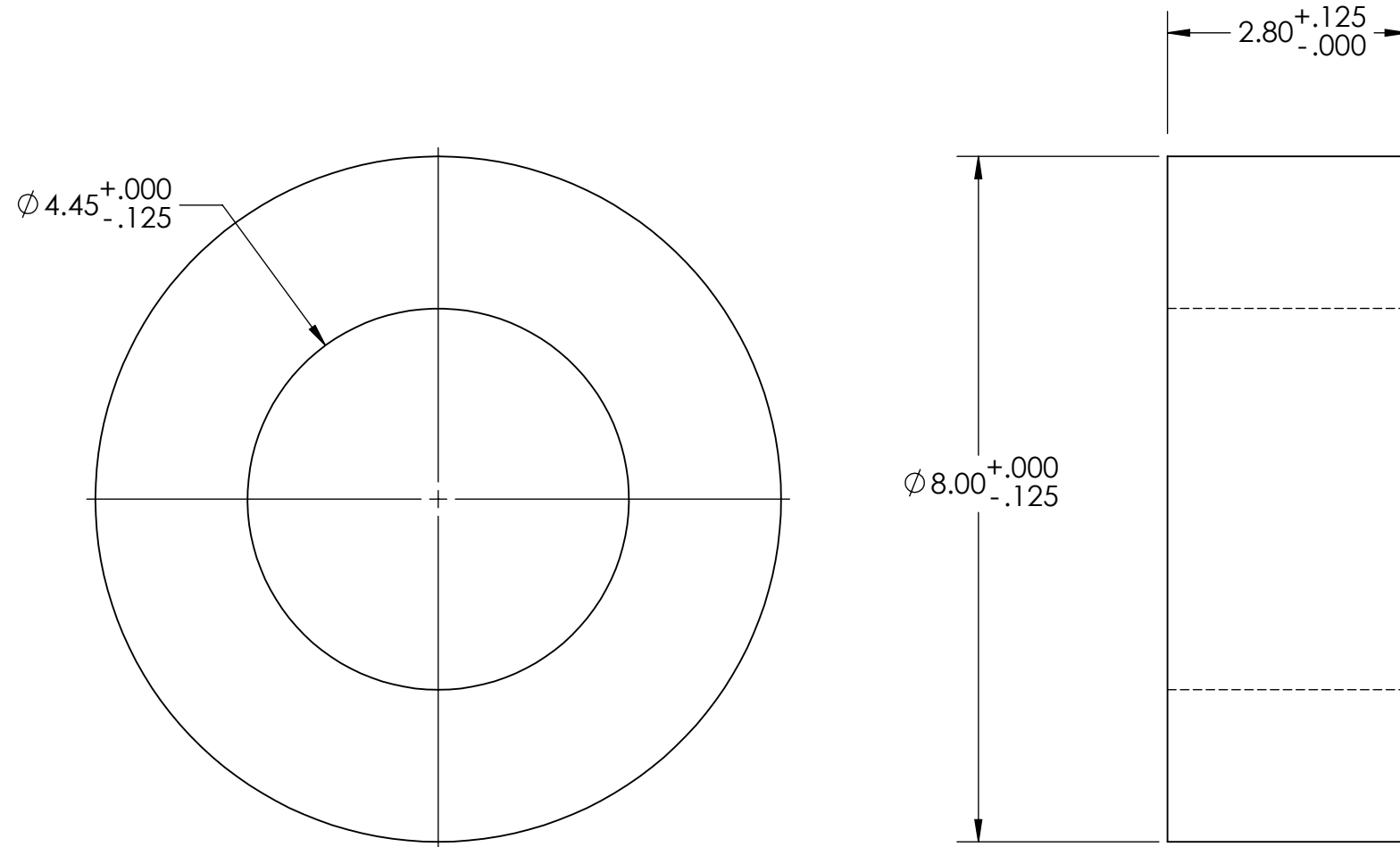

NOTE:
 A: ALL DIMENSION TOLERANCES APPLY AFTER PARTS FINISH
 B: ALL THREADS TO BE PROTECTED FROM COATINGS

THIS DRAWING SUPERCEDES PARTNO: HB45TINH

QTY: 1

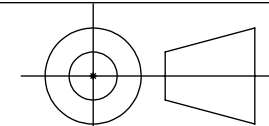

THIRD ANGLE PROJECTION

⊙ ±.002 F.I.M.

// ±.0005 PER INCH

⊥ ±.001 PER INCH

BREAK ALL SHARP EDGES AND DEBURR ALL HOLES .03 MAX

UNLESS OTHERWISE SPECIFIED:

DIMENSIONS ARE IN INCHES
 TOLERANCES: FRACTIONAL ±1/64
 ANGULAR: MACH ±.5 BEND ±1
 ONE PLACE DECIMAL ±.05
 TWO PLACE DECIMAL ±.01
 THREE PLACE DECIMAL ±.005
 FOUR PLACE DECIMAL ±.0005

MATERIAL
ANSI 6061-T651 Aluminum

Hardness, Rc XX-XX

FINISH
NA √u.o.s.

DO NOT SCALE DRAWING

	NAME	DATE
DRAWN	DEH	4/29/2024
CHECKED		
ENG APPR.		
MFG APPR.		
Q.A.		
MAKE/BUY	BUY	
COATING	NA	
COMMENTS:		

HY-CONN

DESCRIPTION:
HP45 BLANKS

SIZE B	DWG. NO. TI45_EXT	REV 00
SCALE: 1:2	WEIGHT: 9.48	SHEET 1 OF 1

PROPRIETARY AND CONFIDENTIAL

THE INFORMATION CONTAINED IN THIS DRAWING IS THE SOLE PROPERTY OF HYCONN COMPANY. ANY REPRODUCTION IN PART OR AS A WHOLE WITHOUT THE WRITTEN PERMISSION OF HYCONN COMPANY IS PROHIBITED.

ALL DRAWINGS AND PRINTS, WHETHER IN PRINTED OR ELECTRONIC FORMAT, MAY ONLY BE USED FOR THE PURPOSE FOR WHICH PERMISSION TO USE WAS GRANTED.

4

3

2

1

B

B

A

A