

REVISIONS				
REV.	DESCRIPTION	BY	DATE	APPROVED
00	INITIAL RELEASE	B.F	05/08/2023	-
1	ADDED 2.39° TO CUT LAND	B.F	6/1/2023	

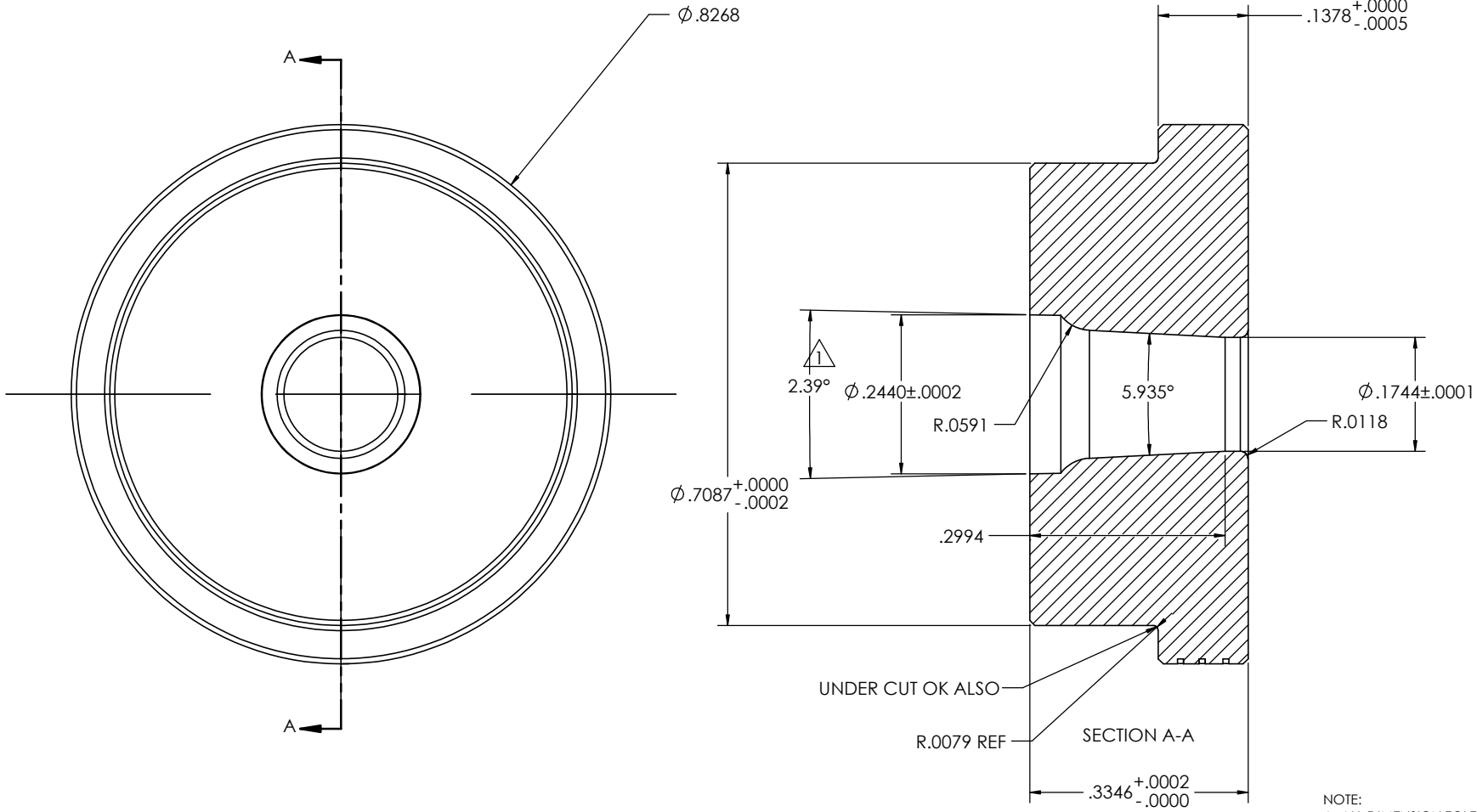

NOTE:  
 A: ALL DIMENSION TOLERANCES APPLY AFTER PARTS FINISH  
 B: ALL THREADS TO BE PROTECTED FROM COATINGS

QTY: 10

**PROPRIETARY AND CONFIDENTIAL**

THE INFORMATION CONTAINED IN THIS DRAWING IS THE SOLE PROPERTY OF D&M HOLDING COMPANY. ANY REPRODUCTION IN PART OR AS A WHOLE WITHOUT THE WRITTEN PERMISSION OF D&M HOLDING COMPANY IS PROHIBITED.

ALL DRAWINGS AND PRINTS, WHETHER IN PRINTED OR ELECTRONIC FORMAT, MAY ONLY BE USED FOR THE PURPOSE FOR WHICH PERMISSION TO USE WAS GRANTED.

THIS DOCUMENT MAY CONTAIN TECHNOLOGY OR TECHNICAL DATA, THE USE OF WHICH IS RESTRICTED BY THE U.S. ARMS EXPORT CONTROL ACT. THIS DATA IS SUBJECT TO THE LIMITATIONS SPECIFIED IN THE INTERNATIONAL TRAFFIC IN ARMS REGULATIONS (ITAR). BY ACCEPTING THIS DATA, THE RECIPIENT AGREES TO HONOR THE REQUIREMENTS OF THE ITAR.

THE INFORMATION ON THIS DOCUMENT MAY NOT BE TRANSFERRED TO ANY OTHER COUNTRY, OR TO A NATIONAL OF ANY OTHER COUNTRY, OR OTHERWISE BE DISPOSED OF IN ANY OTHER COUNTRY, EITHER IN THEIR ORIGINAL FORM OR AFTER BEING INCORPORATED INTO OTHER END-ITEMS IS PROHIBITED BY FEDERAL LAW.

THIRD ANGLE PROJECTION

⊙ ±.002 F.I.M.

∥ ±.0005 PER INCH

⊥ ±.001 PER INCH

BREAK ALL SHARP EDGES AND DEBURR ALL HOLES .03 MAX

UNLESS OTHERWISE SPECIFIED:  
 DIMENSIONS ARE IN INCHES  
 TOLERANCES: FRACTIONAL ±1/64  
 ANGULAR: MACH ±.5 BEND ±1  
 ONE PLACE DECIMAL ±.05  
 TWO PLACE DECIMAL ±.01  
 THREE PLACE DECIMAL ±.005  
 FOUR PLACE DECIMAL ±.0005  
 WATERMARK

HARDNESS: D-2 RC 58-60

FINISH: √u.o.s.

DO NOT SCALE DRAWING

NAME	DATE
DRAWN	B.FRANK
CHECKED	
ENG APPR.	
MFG APPR.	
G.A.	
MAKE/BUY	
COATING	
COMMENTS:	

**D&M Holding Company**

TITLE: SMALL RIFLE DIE SECTION BRUDERER .244

SIZE: C DWG. NO. 02490-01-016-.244 REV 1

SCALE: 8:1 WEIGHT: 0.01 SHEET 1 OF 1